

Heat Exchanger Series

AF1025T Series Air Cooler

Symbol

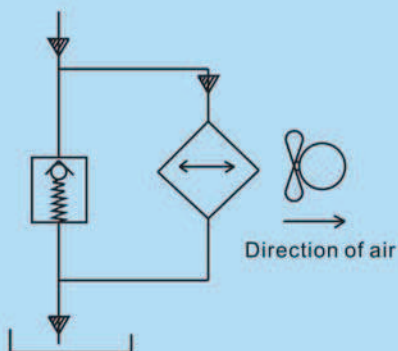

Performance curve

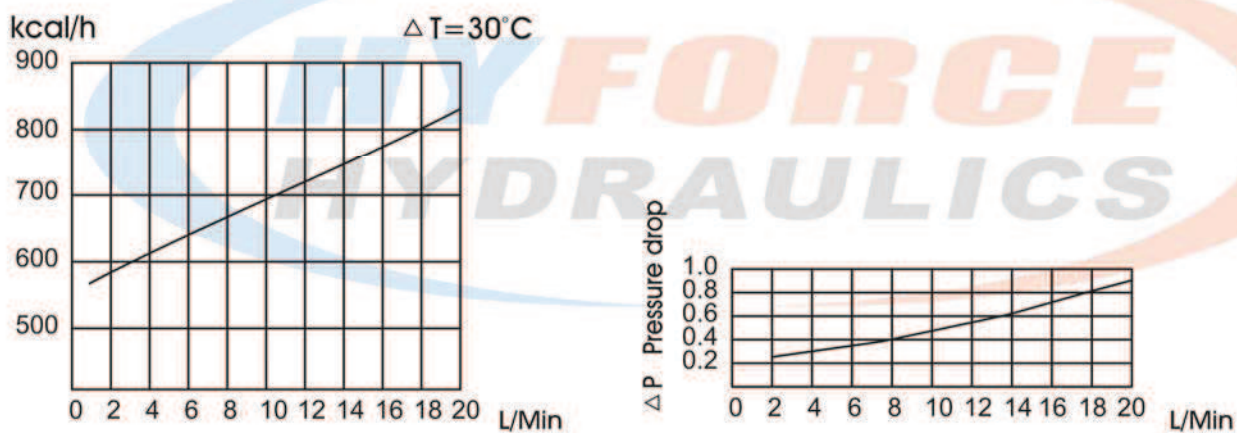

Technical data

Model	Voltage	Max. flow rate (l/min)	Max. working pressure (bar)	Consumed power (W)	Speed (rpm)	Noise (db)	Weight (kg)
AF1025T	DC12V	20	20	18	2500	50	3
	DC24V						
	AC110V (50Hz/60Hz)			38	2620		
	AC220V (50Hz/60Hz)						
AC380V (50Hz/60Hz)							

A

B

C

D

E

F

G

H

I

J

K

L

M

N3

O

P

Heat Exchanger Series

AF1025T series air cooler dimensions

Unit: mm

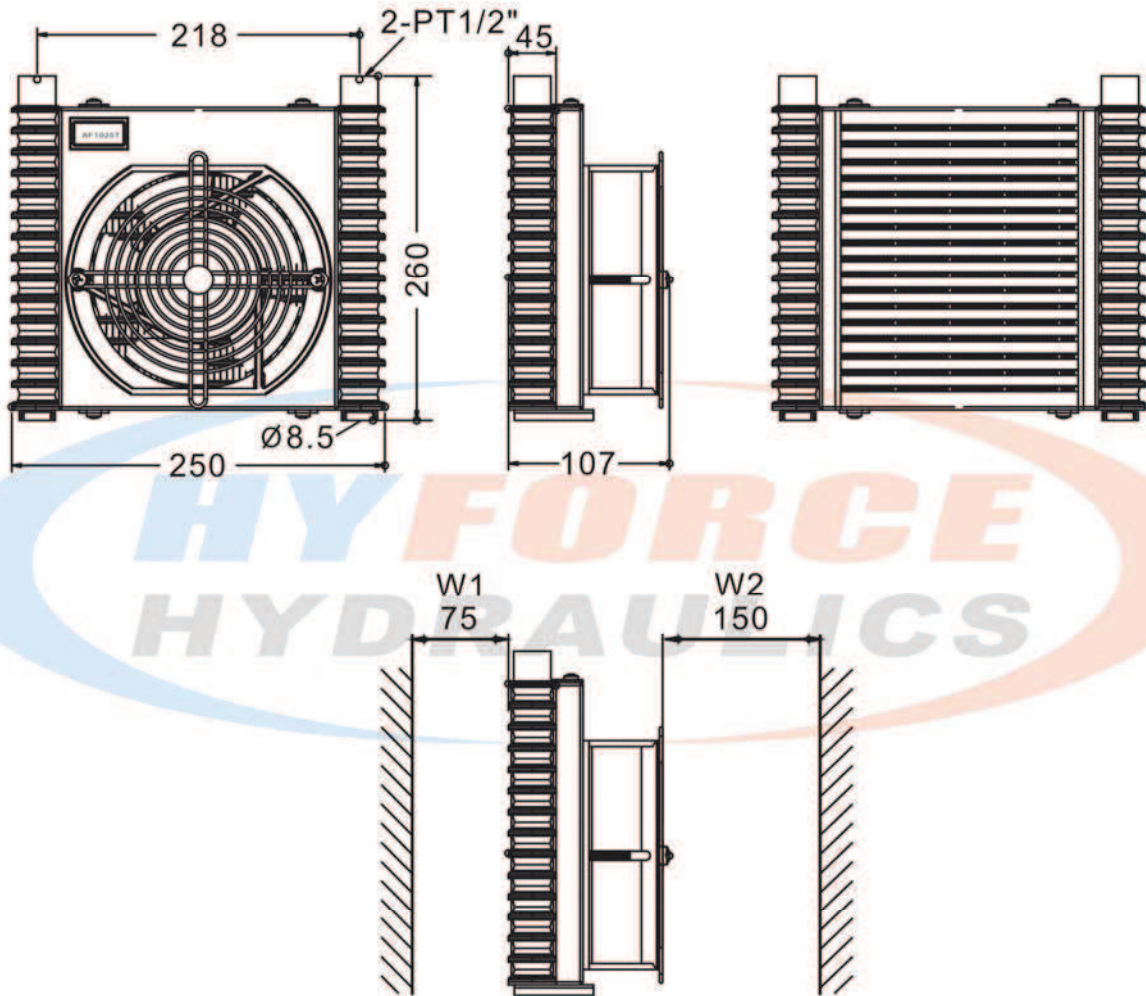

N4

W1 is the min. distance between air inlet and obstacle

W2 is the min. distance between air outlet and obstacle